

**HITACHI**

*BE-IR20 / 21*

# **Infrared B/W Camera Module Operation Guide**

---

Please read this operation Guide carefully for proper operation, and keep it for future refernce.

**Hitachi Kokusai Electric Inc.**

---

# IMPORTANT SAFETY INSTRUCTIONS

## 1. Read Instructions

All the safety and operating instructions should be read before the product is operated.

## 2. Retain Instructions

The safety and operating instructions should be retained for future reference.

## 3. Heed Warnings

All warnings on the product and the operating instructions should be adhered to.

## 4. Follow Instructions

All operating and use instructions should be followed.

## 5. Cleaning

Unplug this product from the wall outlet before cleaning. Do not use liquid cleaners or aerosol cleaners. Use a damp cloth for cleaning.

## 6. Attachments

Do not use attachments not recommended by the product manufacturer as they may cause hazards.

## 7. Water and Moisture

Do not use this product near water - for example, near a bath tub, wash bowl, kitchen sink, or laundry tub; in a wet basement; or near a swimming pool; and the like.

## 8. Accessories

Do not place this product on an unstable cart, stand, tripod, bracket, or table. The product may fall, causing serious injury to a child or adult, and serious damage to the product. Use only with a cart, stand, tripod, bracket, or table recommended by the manufacturer, or sold with the product. Any mounting of the product should follow the manufacturer's instructions, and should use a mounting accessory recommended by the manufacturer.

## 9. Moving

A product and cart combination should be moved with care.

Quick stops, excessive force, and uneven surfaces may cause the product and cart combination to overturn.

## 10. Ventilation

Slots and openings in the cabinet are provided for ventilation and to ensure reliable operation of the product and to protect it from overheating, and these openings must not be blocked or covered.

The openings should never be blocked by placing the product on a bed, sofa, rug, or other similar surface. This product should not be placed in a built-in installation such as a bookcase or rack unless proper ventilation is provided or the manufacturer's instructions have been adhered to.

## 11. Power Sources

This product should be operated only from the type of power source indicated on the marking label. If you are not sure of the type of power supply to your home, consult your product dealer or local power company. For products intended to operate from battery power, or other sources, refer to the operating instructions.

## **12. Grounding or Polarization**

This product is equipped with a three-wire grounding-type plug a plug having a third (grounding) pin. This plug will only fit into a grounding-type power outlet. This is a safety feature. If you are unable to insert the plug into the outlet, contact your electrician to replace your obsolete outlet. Do not defeat the safety purpose of the grounding-type plug.

## **13. Power-Cord Protection**

Power-supply cords should be routed so that they are not likely to be walked on or pinched by items placed upon or against them, paying particular attention to cords at plug, convenience receptacles, and the point where they exit from the product.

## **14. Lightning**

For added protection for this product during a lightning storm, or when it is left unattended and unused for long periods of time, unplug it from the wall outlet. This will prevent damage to the product due to lightning and power-line surges.

## **15. Overloading**

Do not overload wall outlets, extension cords or integral convenience receptacles as this can result in a risk of fire or electric shock.

## **16. Object and Liquid Entry**

Never push objects of any kind into this product through openings as they may touch dangerous voltage points or short-out parts that could result in a fire or electric shock. Never spill liquid of any kind on the product.

## **17. Inflammable and Explosive Substance**

Avoid using this product where there are gases, and also where there are inflammable and explosive substances in the immediate vicinity.

## **18. Heavy Shock or Vibration**

When carrying this product around, do not subject the product to heavy shock or vibration.

## **19. Servicing**

Do not attempt to service this product yourself as opening or removing covers may expose you to dangerous voltage or other hazards. Refer all servicing to qualified service personnel.

## **20. Damage Requiring Service**

Unplug this product from the wall outlet and refer servicing to qualified service personnel under the following conditions:

- a. When the power-supply cord or plug is damaged.
- b. if liquid has been spilled, or objects have fallen into the product.
- c. If the product has been exposed to rain or water.
- d. If the product does not operate normally by following the operating instructions. Adjust only those controls that are covered by the operating instructions as an improper adjustment of other controls may result in damage and will often require extensive work by a qualified technician to restore the product to its normal operation.
- e. If the product has been dropped or damaged in any way.
- f. When the product exhibits a distinct change in performance-this indicates a need for service.

**21. Replacement Parts**

When replacement parts are required, be sure the service technician has used replacement parts specified by the manufacturer or have the same characteristics as the original part.

Unauthorized substitutions may result in fire, electric shock, or other hazards.

**22. Safety Check**

Upon completion of any service or repairs to this product, ask the service technician to perform safety checks to determine that the product is in proper operating condition.

**23. Wall or Ceiling Mounting**

The product should be mounted to a wall or ceiling only as recommended by the manufacturer.

**24. Heat**

The product should be situated away from heat sources such as radiators, heat registers, stoves, or other products (including amplifiers) that produce heat.

# WICHTIGE SICHERHEITSANWEISUNGEN

## 1. Alle Anweisungen lesen.

Vor Betrieb des Erzeugnisses sollten alle Sicherheits- und Bedienungsanleitungen gelesen werden.

## 2. Die Anweisungen aufbewahren.

Die Sicherheits- und Bedienungsanleitungen sollten fünftigen Bezug aufbewahrt werden.

## 3. Warnungen beachten.

Die Warnungen auf dem Erzeugnis und in den Bedienungsanleitungen sollten beachtet werden.

## 4. Anweisungen befolgen.

Alle Bedienungsanleitung- und Verwendungsanweisungen sollten befolgt werden.

## 5. Reinigung

Den Stecker des Geräts vor Reinigung aus der Steckdose ziehen. Keine flüssigen Reinigungsmittel oder Aerosolreiniger verwenden. Zum Reinigen einen feuchten Lappen verwenden.

## 6. Zubehör

Nur vom Hersteller des Erzeugnisses empfohlenes Zubehör verwenden, da es sonst zu Störungen kommen kann.

## 7. Wasser und Feuchtigkeit

Dieses Erzeugnis nicht in der Nähe von Wasser verwenden - z.B. in der Nähe einer Badewanne, eines Waschbeckens, einer Küchenspüle, eines Waschzubers, in einem nassen Keller, in der Nähe eines Schwimmbeckens usw.

## 8. Aufstellung

Das Erzeugnis nicht auf einen instabilen Wagen, Stand, Dreifuß, Träger oder Tisch stellen.

Das Erzeugnis kann sonst herunterfallen und ein Kind oder einen Erwachsenen schwer verletzen.

Außerdem kann das Gerät schwer beschädigt werden. Nur mit einem Wagen, Stand, Dreifuß, Träger oder Tisch verwenden, der vom Hersteller empfohlen oder mit dem Erzeugnis verkauft worden ist. Für jegliche Anbringung sollten die Anweisungen des Herstellers befolgt werden, und das vom Hersteller empfohlene Anbringungs Zubehör sollte verwendet werden.

## 9. Eine Kombination von Erzeugnis und Wagen sollte vorsichtig bewegt werden.

Schneller Halt, übermäßige Krafteinwirkung und unebene Oberflächen können Umkippen der Kombination von Erzeugnis und Wagen verursachen.

## 10. Ventilation

Schlitze und Öffnungen im Gehäuse dienen der Ventilation. Sie sind für zuverlässigen Betrieb des Gerätes und Schutz vor Überhitzung erforderlich und dürfen nicht blockiert oder abgedeckt werden.

Die Öffnungen sollten niemals dadurch blockiert werden, daß das Gerät auf ein Bett, ein Sofa, einen Teppich oder eine ähnliche Oberfläche gestellt wird.

Das Gerät sollte nur dann in Einbauinstallation wie in einem Bücherschrank oder einem Gestell verwendet werden, wenn angemessene Ventilation vorgesehen ist bzw. Die Anweisungen des Herstellers befolgt worden sind.

## **11. Stromversorgung**

Dieses Erzeugnis sollte nur an der auf dem Typenschild angegebenen Stromversorgungsart betrieben werden. Wenn Sie nicht sicher sind, was für eine Stromversorgung Sie haben, so wenden Sie sich bitte an Ihren Erzeugnishändler oder an das lokale Elektrizitätswerk. Beziehen Sie sich für Batteriebetrieb oder andere Stromquellen vorgesehene Erzeugnisse bitte auf die Bedienungsanleitungen.

## **12. Erdung oder Polarisierung**

Dieses Erzeugnis ist mit einem Schutzkontaktstecker mit drei Leitern ausgerüstet, mit einem Erdungskontakt. Dieser Stecker paßt nur in ein schuko-Steckdose. Dies ist eine Sicherheitsmaßnahme. Wenn Sie den Stecker nicht in die Steckdose stecken können, so wenden Sie sich bitte an ihren Elektriker, damit er die veraltete Schutz des Schutzkontaktsteckers unwirksam.

## **13. Netzkabelschutz**

Netzkabel sollten so verlegt werden, daß möglichst nicht darauf getreten wird und daß sie nicht eingeklemmt werden, mit besonderer Beachtung der Kabel an Stackern, Verlängerungskabeln und dem Austritt des Kabels aus dem Erzeugnis.

## **14. Blitzschlag**

Für zusätzlichen Schutz des Erzeugnisses während eines Gewitters oder bei Nichtverwendung für lange Zeit den Stecker aus der Steckdose ziehen. Dies verhütet Beschädigung durch Blitzschlag und Netzspannungstöße.

## **15. Überlastung**

Wandsteckdosen, Verlängerungskabel und eingebaute Bequemlichkeitssteckdosen nicht überlasten, da dies Feuer oder elektrischen Schlag verursachen kann.

## **16. Eindringen von Fremdkörpern und Flüssigkeit**

Niemals Objekte irgendwelcher Art durch die Öffnungen in das Gerät schieben, da diese unter hoher Spannung stehende Teile berühren oder kurzschließen können, wodurch es zu Feuer oder elektrischem Schlag kommen kann. Niemals Flüssigkeiten irgendwelcher Art auf das Erzeugnis verschütten.

## **17. Entflammbare und explosive Substanzen**

Vermeiden Sie Verwendung dieses Erzeugnisses an Orten mit Gasen bzw. entflammbaren oder explosiven Substanzen in der direkten Umgebung.

## **18. Starke stöße oder Vibrationen**

Setzen Sie das Erzeugnis beim Transport nicht starken Stößen oder Vibrationen aus.

## **19. Wartung**

Versuchen Sie nicht, dieses Erzeugnis Selbst zu warten, da Sie sich durch Öffnen bzw. Entfernen von Abdeckungen hohen Spannungen und sonstigen Gefährdungen aussetzen können.

Beziehen Sie sich für jegliche Wartung auf qualifiziertes Wartungspersonal.

## **20. Beschädigung, die Wartung erfordert**

Ziehen Sie den Stecker dieses Erzeugnisses aus der Steckdose und wenden Sie sich an qualifiziertes Wartungspersonal, wenn eine der folgenden Bedingungen vorliegt:

- a. Wenn das Netzkabel oder der Stecker beschädigt ist.
- b. Bei Eindringen von Flüssigkeit oder Fremdkörpern in das Gerät.
- c. Wenn das Erzeugnis Regen oder Wasser ausgesetzt worden ist.
- d. Wenn das Erzeugnis bei Befolgen der Bedienungsanleitungen nicht normal funktioniert.

Nur die Regelelemente verstellen, die in den Bedienungsanleitungen behandelt werden, da unangemessene Einstellung anderer Regelelemente Beschädigung verursachen kann und oft beträchtliche Arbeit durch einen qualifizierten Techniker erfordert, um das Erzeugnis wieder, zu normalem Betrieb zurückzubringen.

- e. Wenn das Erzeugnis fallen gelassen oder beschädigt worden ist.
- f. Wenn das Erzeugnis eine klare Änderung in der Leistung zeigt-dies weist darauf hin, daß Wartung erforderlich ist.

## **21. Ersatzteile**

Wenn Ersatzteile erforderlich sind, darauf achten, daß der Wartungstechniker nur die vom Hersteller festgelegten Ersatzteile oder Teile mit den gleichen Charakteristiken wie die ursprünglichen Teile verwendet. Unautorisierte Ersatzteile können Feuer, elektrischen Schlag oder sonstige Gefährdungen verursachen.

## **22. Sicherheitsprüfung**

Bitten Sie den Wartungstechniker nach der Vollendung von Wartung oder Reparaturarbeiten an diesem Erzeugnis um die Durchführung von Sicherheitsprüfungen, um zu bestimmen, daß das Erzeugnis im angemessenen Betriebszustand ist.

## **23. Anbringung an der Wand oder an der Decke**

Das Erzeugnis sollte nur entsprechend den Empfehlungen des Herstellers an einer Wand oder an der Decke angebracht werden.

## **24. Wärme**

Das Erzeugnis sollte fern von Wärmequellen wie Radiatoren, Heizwiderständen, Öfen und anderen Wärme erzeugenden Erzeugnissen (einschließlich Verstärkern) aufgestellt werden.

# MISES EN GARDE IMPORTANTES

## 1. Lire les instructions

Lire toutes les instructions de sécurité et de fonctionnement avant de faire fonctionner l'appareil.

## 2. Conserver ces instructions

Conserver les instructions de sécurité et de fonctionnement à des fins de référence ultérieure.

## 3. Tenir compte des avertissements

Tous les avertissements qui figurent sur l'appareil et dans le mode d'emploi devront être respectés.

## 4. Observer les instructions

Observer toutes les instructions de fonctionnement et d'utilisation.

## 5. Nettoyage

Avant de procéder au nettoyage, débrancher l'appareil de la prise secteur. Ne pas utiliser de produits de nettoyage liquides ou en aérosol.

Nettoyer l'appareil avec un chiffon humide.

## 6. Fixations

Ne pas utiliser de fixations non recommandées par le fabricant de l'appareil car elles pourraient être source de danger.

## 7. Eau et humidité

Ne pas utiliser l'appareil à proximité d'eau-par exemple près d'une baignoire, d'un lavabo, d'un évier ou d'un bac à lessive, dans un sous-sol humide, ou près d'une piscine, etc.

## 8. Accessoires

Ne pas placer l'appareil sur un chariot, un socle, un pied, un support ou une table instables. L'appareil pourrait tomber, blessant grièvement des enfants ou des adultes, et étant sérieusement endommagé.

Utiliser exclusivement le chariot, le socle, le pied, le support ou la table recommandés par le fabricant, ou vendus avec l'appareil. Pour tout montage de l'appareil, respecter les instructions du fabricant, et utiliser à cette fin l'accessoire de montage recommandé par le fabricant.

## 9. L'appareil monté sur son chariot devra être déplacé avec précaution.

Des arrêts brusques, une force excessive et des surfaces irrégulières pourraient provoquer le renversement de l'ensemble appareil-chariot.

## 10. Ventilation

Les fentes et les ouvertures du coffret sont prévues pour la ventilation ainsi que pour garantir un fonctionnement en toute sécurité de l'appareil et le protéger de toute surchauffe, et ces ouvertures ne devront donc être ni obstruées ni recouvertes. Ne jamais obstruer les ouvertures en plaçant l'appareil sur un lit, un sofa, un tapis ou toute surface similaire. Ne jamais placer l'appareil dans un support confiné, par exemple une bibliothèque ou une étagère, sans ventilation suffisante ou sans respecter les instructions du fabricant.

## 11. Sources d'alimentation

L'appareil devra être alimenté exclusivement sur le type d'alimentation indiqué sur l'étiquette signalétique. Si l'on n'est pas sûr du type d'alimentation du local, consulter le revendeur de l'appareil ou la compagnie d'électricité locale. Pour les appareils qui fonctionnent sur batterie ou sur d'autres sources, voir le mode



d'emploi.

## **12. Mise à la terre ou polarisation**

L'appareil est doté d'une fiche trifilaire avec mise à la terre, dont la troisième broche assure la mise à la terre. Cette fiche ne rentrera que dans les prises trifilaires de mise à la terre. Ceci est une mesure de sécurité. Si la fiche ne rentre pas dans la prise, faire remplacer la prise défectueuse par un électricien.

Ne pas rendre vaine la mesure de sécurité assurée par cette prise avec mise à la terre.

## **13. Protection du cordon d'alimentation**

Acheminer les cordons d'alimentation de façon qu'on ne risque pas de marcher dessus ou de les coincer sous un objet placé dessus ou contre eux.

Faire particulièrement attention aux fiches des cordons, à la proximité des prises, et à l'endroit où ils ressortent de l'appareil.

## **14. Foudre**

Pour renforcer la protection de l'appareil pendant un orage, ou si l'on s'en éloigne ou qu'on reste longtemps sans l'utiliser, le débrancher de la source d'alimentation. Ceci permettra d'éviter tout dommage de l'appareil dû à la foudre et aux surtensions de ligne.

## **15. Surcharge**

Ne pas surcharger les prises, rallonges et prises multiples car cela pourrait entraîner un risque de feu ou de choc électrique.

## **16. Pénétration d'objets et de liquides**

Ne jamais enfoncer d'objets d'aucune sorte dans les ouvertures de l'appareil car ils pourraient toucher des points de tension dangereuse ou court-circuiter des pièces, ce qui pourrait provoquer un feu ou un choc électrique. Ne jamais renverser de liquide d'aucune sorte sur l'appareil.

## **17. Substances inflammables et explosives**

Eviter d'utiliser l'appareil en présence de gaz, ainsi qu'à proximité immédiate de substances inflammables et explosives.

## **18. Chocs ou vibrations violents**

Lorsqu'on transporte l'appareil, ne pas le soumettre à des chocs ou des vibrations violents.

## **19. Réparations**

Ne pas tenter de réparer l'appareil soi-même car le fait d'ouvrir ou de retirer les caches risque d'exposer l'utilisateur à des tensions dangereuses notamment. Confier toute réparation à un personnel qualifié.

## **20. Dommages nécessitant réparations**

Débrancher l'appareil de la source d'alimentation et confier les réparations à un personnel qualifié dans les cas suivants:

- a. Lorsque le cordon d'alimentation ou sa fiche sont endommagés
- b. Si du liquide s'est renversé sur l'appareil ou que des objets sont tombés dedans
- c. Si l'appareil a été exposé à la pluie ou à l'eau.
- d. Si l'appareil ne fonctionne pas normalement lorsqu'on observe les instructions d'utilisation.

Ne régler que les commandes couvertes par le mode d'emploi ; en effet, un réglage incorrect des autres commandes pourrait entraîner des dommages et nécessiteront souvent des travaux de réparation coûteux par un technicien qualifié pour remettre l'appareil en état de marche.

- e. Si l'appareil est tombé ou qu'il a été endommagé.
- f. Si l'appareil affiche une nette modification de ses performances, cela signifie qu'il a besoin d'être réparé.

### **21. Pièces de rechange**

Si l'on a besoin de pièces de rechange, veiller à ce que le technicien de réparation utilise exclusivement les pièces de rechange spécifiées par le fabricant ou des pièces ayant les mêmes caractéristiques que les pièces d'origine. Les pièces de rechange non autorisées risquent de provoquer un feu, un choc électrique et autres dangers.

### **22. Vérification de sécurité**

Après tout travail d'entretien ou de réparation de l'appareil, demander au technicien de réparation d'effectuer les vérifications de sécurité pour s'assurer que l'appareil est en bon état de marche.

### **23. Montage au mur ou au plafond**

L'appareil ne pourra être monté au mur ou au plafond que de la manière recommandée par le fabricant.

### **24. Chaleur**

Eloigner l'appareil des sources de chaleur, telles que radiateurs, appareils de chauffage, cuisinières, et de tout produit engendrant de la chaleur (y compris les amplificateurs).

# IMPORTANT NOTICE

For USA

These products have been tested and found to comply with the limits for a Class A digital device, pursuant to Part 15 of the FCC Rules. These limits are designed to provide reasonable protection against harmful interference when the equipment is operated in a commercial environment. This equipment generates, uses, and can radiate radio frequency energy and, if not installed and used in accordance with the instruction manual, may cause harmful interference to radio communications. Operation of this product in a residential area is likely to cause harmful interference in which case the user will be required to correct the interference at his own expense.

## WARNING

Changes or modifications not expressly approved by Hitachi Denshi responsible for compliance could void the user's authority to operate the equipment.

For Canada

This product does not exceed the class A/class B limits for radio noise emissions from digital apparatus as set out in the radio interference regulations.

Le présent appareil n'émet pas de bruits radioélectriques dépassant les limites applicable aux appareils numériques de classe A prescrites dans le rVglement sur le brouillage radioélectrique édicter par le ministère des communications du canada.

# Table of Contents

1. Introduction .....	2
2. General .....	2
3. Composition .....	2
4. Specifications .....	2
5. Notes to users .....	4
6. External view .....	6
7. Optical dimensions .....	6
8. Installation .....	7
9. Typical connection .....	8
10 . External sync (BE-IR21) .....	10
11 . Function settings and changes	
11-1 AGC on / off .....	12
11-2 Gamma response .....	13
11-3 Auto electronic shutter on / off .....	14
11-4 Changes to fixed shutter mode .....	15
11-5 BE-IR20 external sync .....	16
11-6 BE-IR21 internal sync .....	17
11-7 HD and VD output (BE-IR20 only) .....	18
12 . Options	
Mount adapter LA-IR20 .....	19
Attachment : Spectral sensitivity characteristic .....	21

## 1. Introduction

Thank you very much for your purchase of the Hitachi BE-IR20/21 Black and White Camera Module.

Prior to using this camera , read this manual carefully.

## 2. General

The Hitachi BE-IR20/21 are black and white camera modules using a 1/4 inch interline CCD. The BE-IR20/21 are so small that they are most suitable for use with the equipment provided with limited space.

BE-IR20 : Internal sync

BE-IR21 : External sync

## 3. Composition

- 1) Black and white camera module ..... 1
- 2) Interface cable ..... 1

Note : The standard accessory cable is 300 mm signal conductor.

Different length cable requires shielding to avoid external noise.

## 4. Specifications

1) Imaging device	1/2 inch interline CCD
No. of pixels	EIA : 811(H) × 508(V) CCIR : 795(H) × 596(V)
No. of effective pixels	EIA : 768(H) × 494(V) CCIR : 752(H) × 582
Pixel pitch	EIA : 8.4(H) × 9.8(v)μm CCIR : 8.6(H) × 8.3(V)μm
2) Sensing area	EIA : 6.45(H) × 4.84(V)mm CCIR : 6.47(H) × 4.83(V)mm
3) Signal format	Conforming to EIA or CCIR.
4) Scanning system	2:1 interlaced
5) Hor. scanning frequency	EIA : 15.734 kHz CCIR : 15.625 kHz
6) Vert. scanning frequency	EIA : 59.94 Hz CCIR : 50 Hz
7) Sync system	BE-IR20 : Internal sync BE-IR21 : External sync

8) External sync input	HD & VD : 5V peak-to-peak negative Input impedance : 1k $\Omega$ Frequency deviation : $\pm 1\%$
9) Video output	1.0 Vp-p, 75 $\Omega$ , unbalanced Video component : 0.7 Vp-p Sync component : 0.3 Vp-p negative
10) Resolution	EIA : 570(H) $\times$ 380(V) TV lines CCIR : 560(H) $\times$ 380(V) TV lines
11) Signal to noise ratio	56 dB
12) Auto electronic shutter	Provided (factory setting OFF)
13) Automatic gain control (AGC)	Max. 32 dB approx. Fixed gain(factory setting)
14) Integration mode	Field integration mode
15) Gamma correction	0.45 ON (factory setting) or OFF Selected by changing chip parts
16) Sensitivity	30 lux , F4, 3200k
17) Minimum illumination	0.3 lux , F1.4 , AGC and gamma on
18) Power supply voltage	9 $\pm$ 0.5 VDC
19) Power consumption	Approx. 160mA
20) Ambient conditions	Operating : -5 to 45 , 90% RH or less Storage : -10 to 60 , 70% RH or less
21) External dimensions	34(W) $\times$ 34(H) $\times$ 20(D) mm
22) Mass	Approx. 17 grams (w/o cable)
23) Options	Mount adaptor LA-IR20

## 5. Notes to users

### ◆ Power supply

- Connect a 9V DC voltage (8.5 to 9.5V) from an external regulated DC power supply.
- Use a stable power supply without ripple and noise.
- Prior to turning on the power switch , check that the polarities of the power cable are correct , referring to the connection diagram (Page 8 , 9)

### ◆ To protect CCD (sensor)

- Do not touch the glass surface of the CCD sensor to avoid deterioration in picture quality due to dirt and scratches.
- If the glass surface of the sensor should become dusty or dirty , remove dust or dirt carefully with a cotton-tipped applicator. Do not wipe the surface with dry cloth or paper tissue to avoid possible damage to the glass surface by static electricity.

### ◆ Protection of camera

- Do not use or store the camera under direct sunlight , at a place exposed to rain or snow , or at a place where flammable or corrosive gas is present.
- When housing the camera in a camera case , use the utmost care regarding rise of internal temperature.

When casing the camera , the temperature normally rises by 10 to 20 , compared with the outside air temperature. The camera operates in the temperature range from -5 to 45 . If the camera is used or left in high temperature environment for hours , the life of the camera may be shortened.

- Do not drop the camera. Do not apply strong shock or vibration to the camera.
- Before connecting or disconnecting a connector , turn off the camera and be sure to hold connector body to connect or disconnect the connector.

### ◆ Camera arrangement

- Mutual interference noise can occur if multiple cameras are arranged in close proximity. Separate the cameras to the extent possible.

When camera units are installed directly into other equipment , external noise can prevent a normal picture. In such cases , shield the camera units.

The camera can be damaged by static electricity. Use ample care when installing and arranging.

### ◆ Auto electric shutter

- In regions using 50 Hz power line frequency , flicker can appear on the monitor screen from light sources such as fluorescent or mercury. In such cases , release the auto electronic shutter.

◆ Phenomena inherent to CCD imaging device

Following are phenomena inherent to a CCD imaging device , and not defects.

- Smear and blooming

When strong light (lamp , fluorescent lamp , reflected light , etc.) is shot , pale bands are displayed vertically above and below the light.

In this case , change the angle of the camera so that such strong light does not enter the camera through the lens.

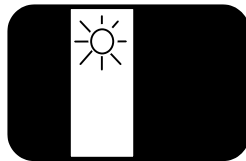

- Fixed pattern noise

When the camera is operated in a high temperature , fixed pattern noise may appear on the entire screen.

The higher the sensitivity of camera , the more this fixed pattern noise appears.

- Moire

When fine patterns are shot , moire may be displayed.

- The CE mark is required when exporting to Europe. Obtain the necessary authorization for the customer's system. Enclose the camera in a shielded case and use shielded cable.



## 6. External view

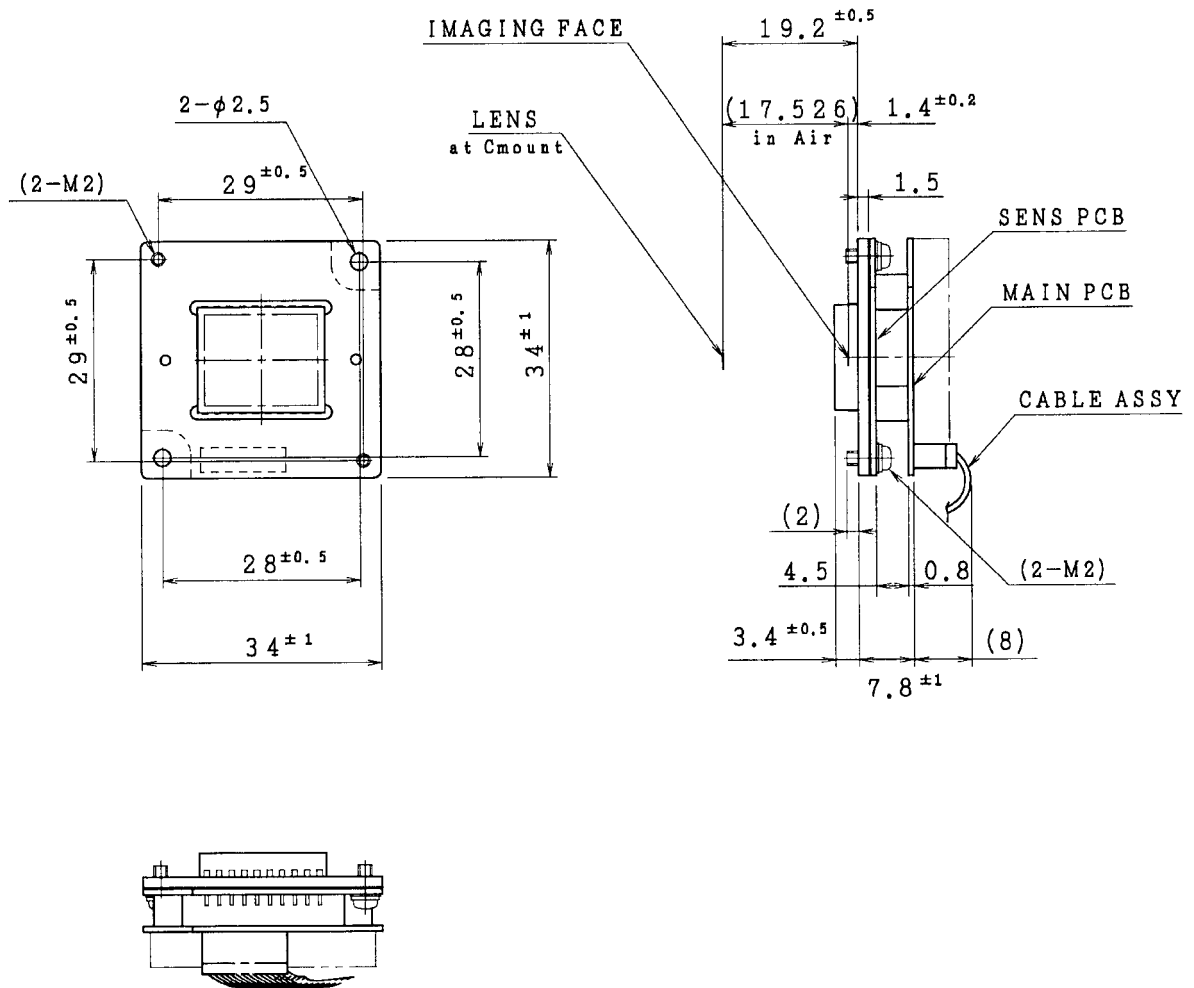

Dimensions

## 7. Optical dimensions

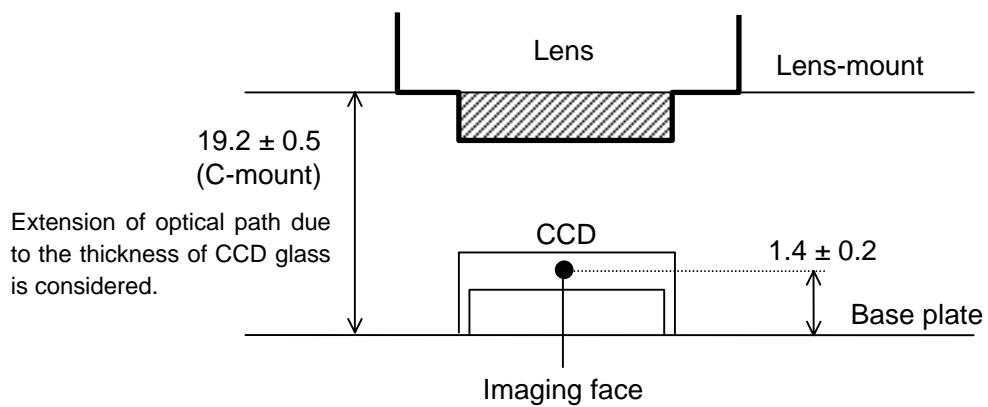

## 8. Installation

When installing the camera in a housing or unit of equipment, secure with two M2 screws inserted into the 2.5 mm diameters holes of the SENS board base plate.

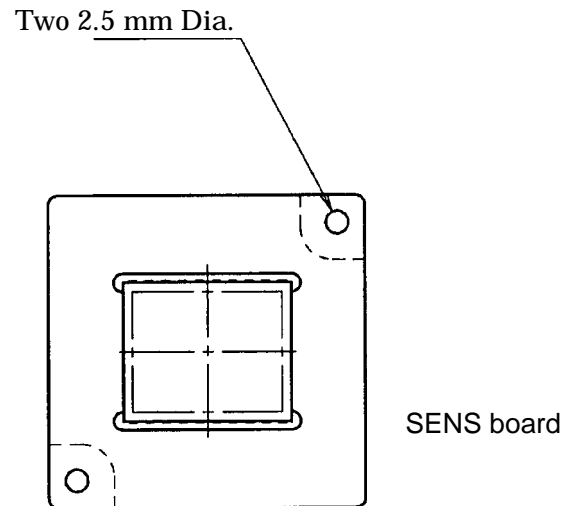

- Notes :
1. Use the SENS board holds to install the camera. Avoid using only the Main board, due to risk of damage to the board connector.
  2. Avoid unnecessary stress on the printed board when engaging and disengaging the connectors.
  3. The screws securing the base plate and SENS board protrude a maximum of 2 mm from the base plate. Observe these screws do not contact the housing or installed equipment.

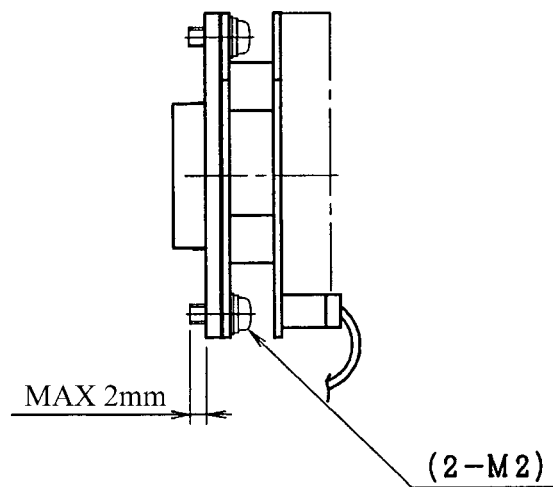

## 9. Typical connection

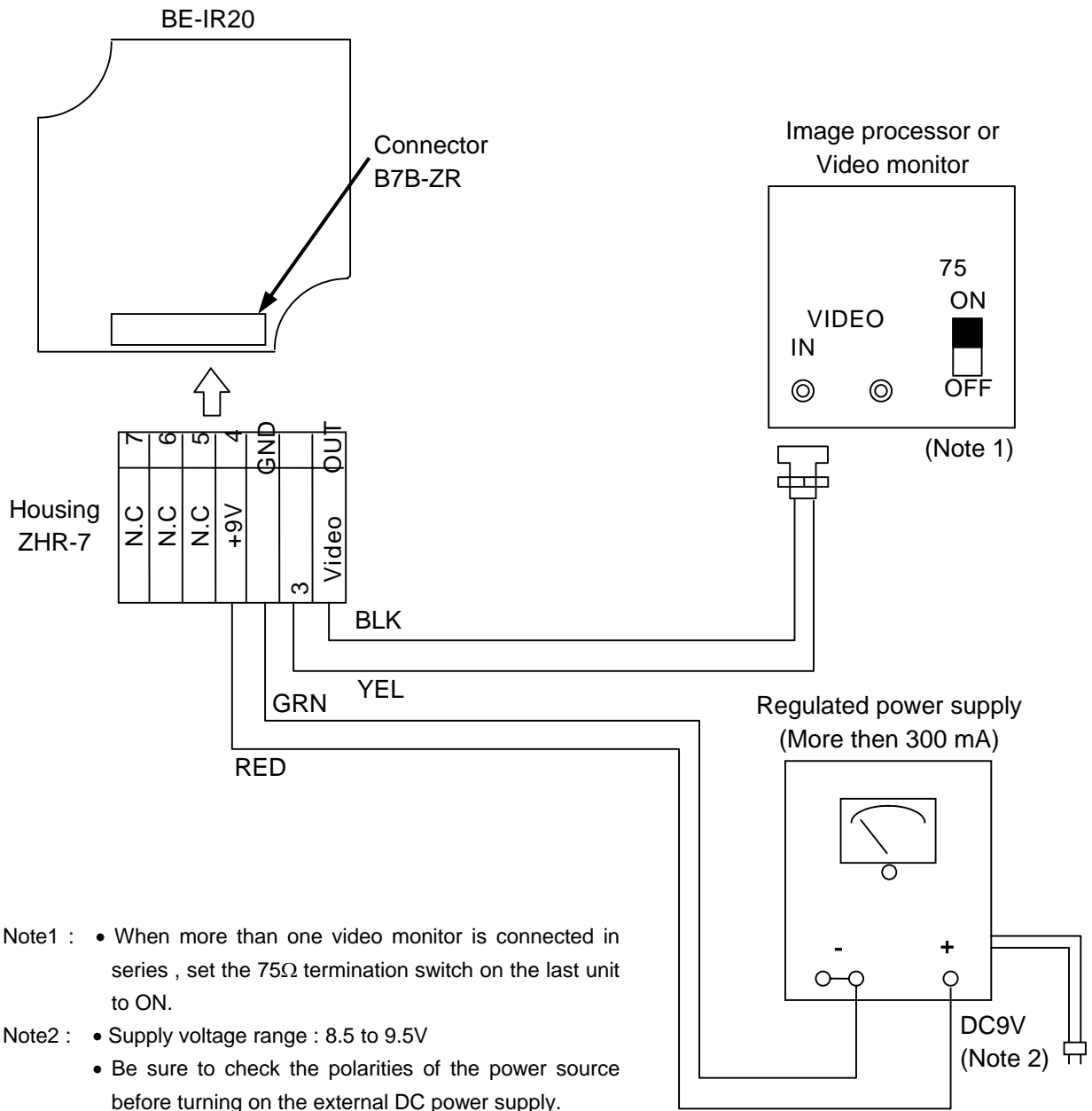

## 9. Typical connection

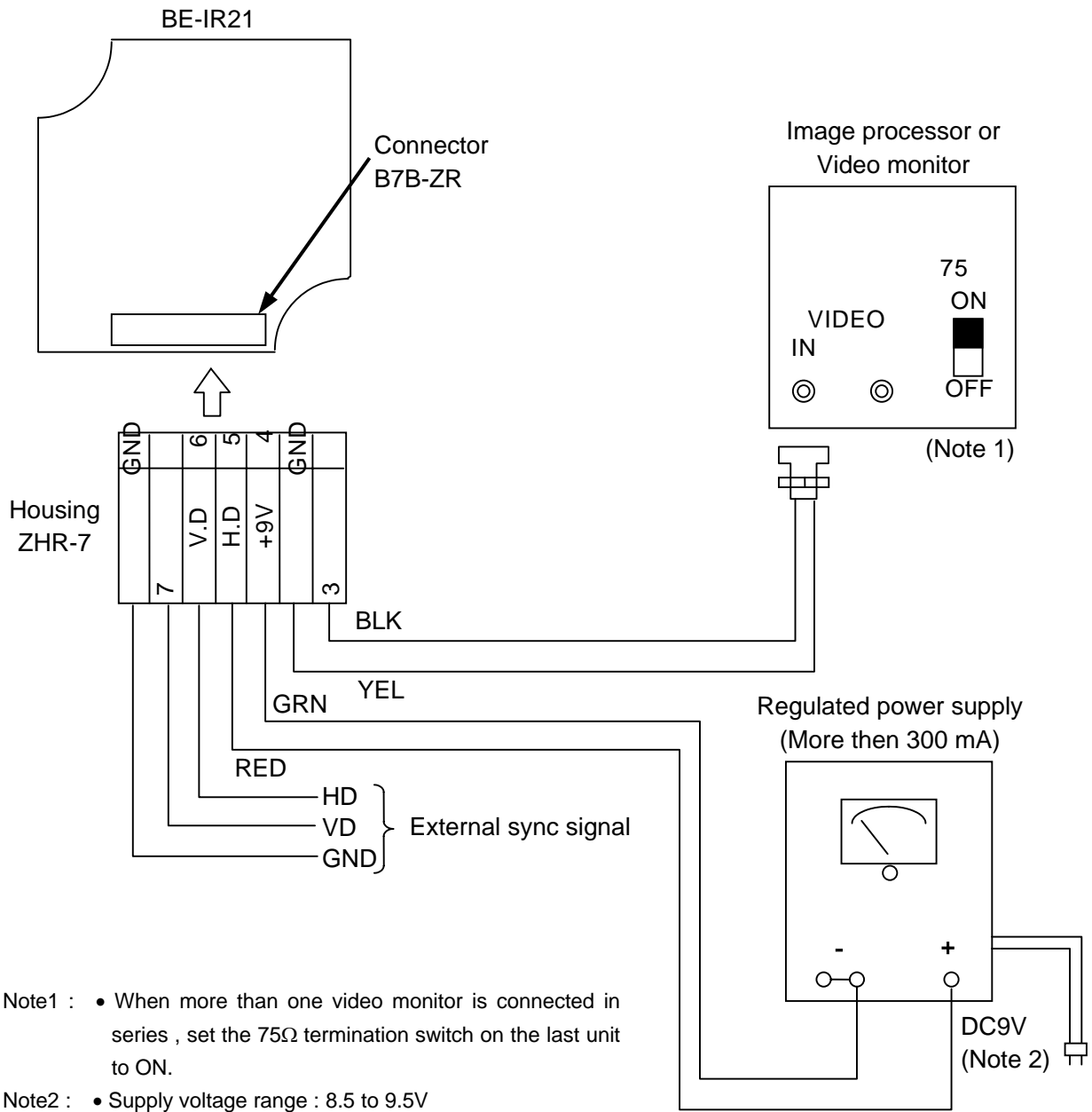

Note1 : • When more than one video monitor is connected in series , set the 75Ω termination switch on the last unit to ON.

Note2 : • Supply voltage range : 8.5 to 9.5V  
 • Be sure to check the polarities of the power source before turning on the external DC power supply.

## 10. External sync (BE-IR21)

Supply sync signals (HD and VD) for BE-IR21 operation. Refer to connection on page 9.

- Horizontal and vertical drive signal inputs  
HD EIA:  $f(H) = 15.734 \text{ kHz} \pm 1 \%$   
VD EIA:  $f(V) = 59.94 \text{ Hz}$  ( $f(V) = f(H) \div 262.5$ )
- Input level  
HD 4 to 6 Vp-p negative  
VD 4 to 6 Vp-p negative
- Input impedance 1 k

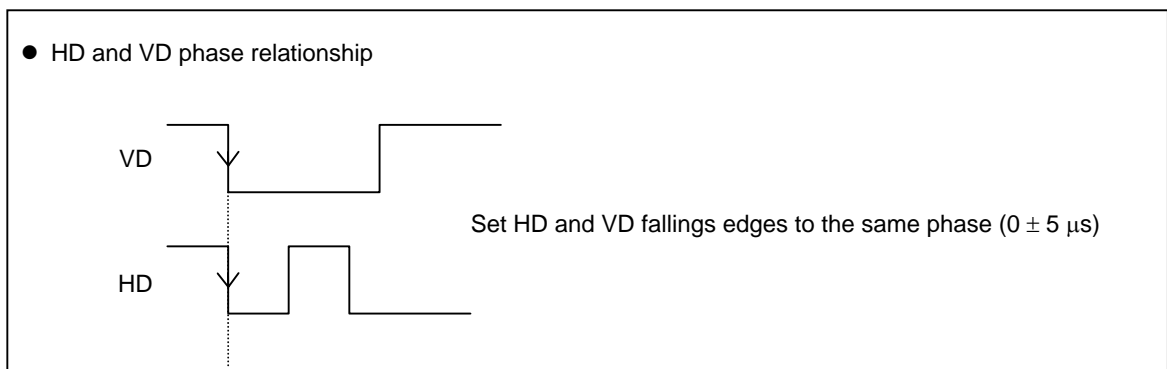
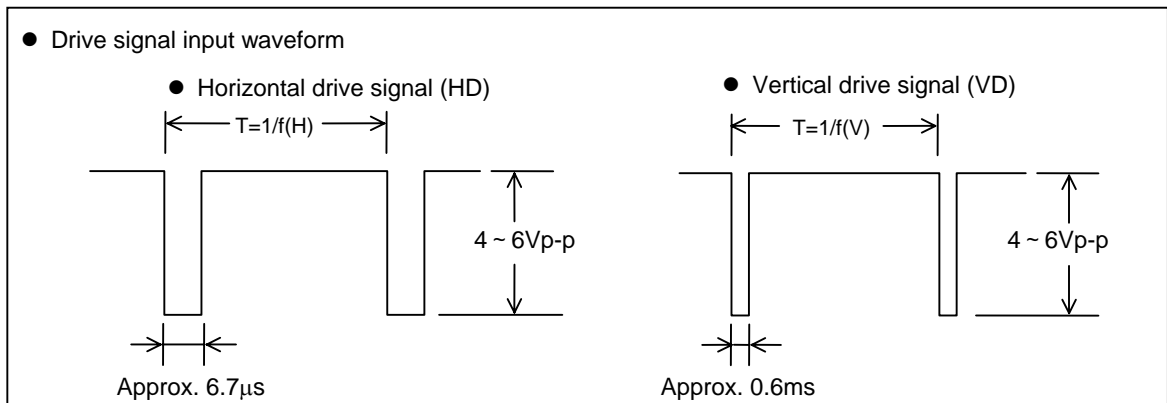

## 11. Function setting and changes

When changing the function settings , perform the work with thorough care. Be sure to use anti-static measures such as a grounding band. Also observe safety precautions when soldering to avoid burn and fire hazards.

Hitachi Denshi assumes on liability for damage or injury resulting from such work.

Since the function setting can be provided at the time of shipment , consult a Hitachi Denshi representative.

### 11-1 AGC on / off

Factory setting is AGC off (fixed gain). If necessary in the application, AGC can be set to on.

When the AGC is off, the gain can be changed by turning RV201.

Set AGC on by changing the indicated chip parts.

Gain	R211	R212	Factory setting
fixed gain	0Ω	Absent	
AGC	Remove	0Ω	

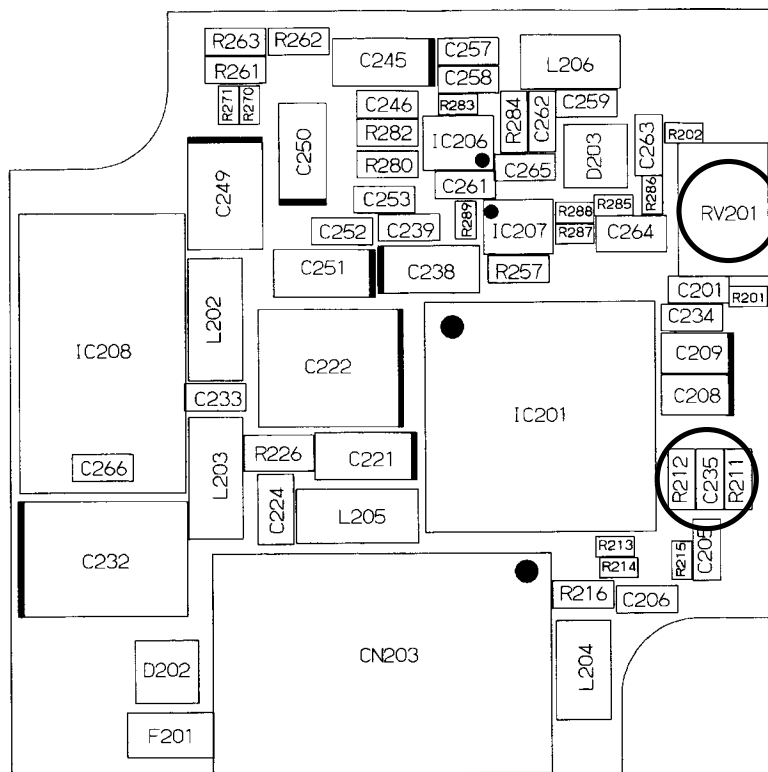

Location of chip resistor (Main board side A)

# 11. Function setting and changes

## 11-2 Gamma response

The factory setting is gamma on. If necessary, the gamma response can be changed as follows.

Change the gamma response by changing the chip part.

Gamma( $\gamma$ )response	R217	R218	R219	Factory setting
ON	Absent	0 $\Omega$	0 $\Omega$	
OFF	0 $\Omega$	Remove	Remove	

0 $\Omega$  : Part code                    RME1784  
 Description                    ERJ3GEYJ0R00V

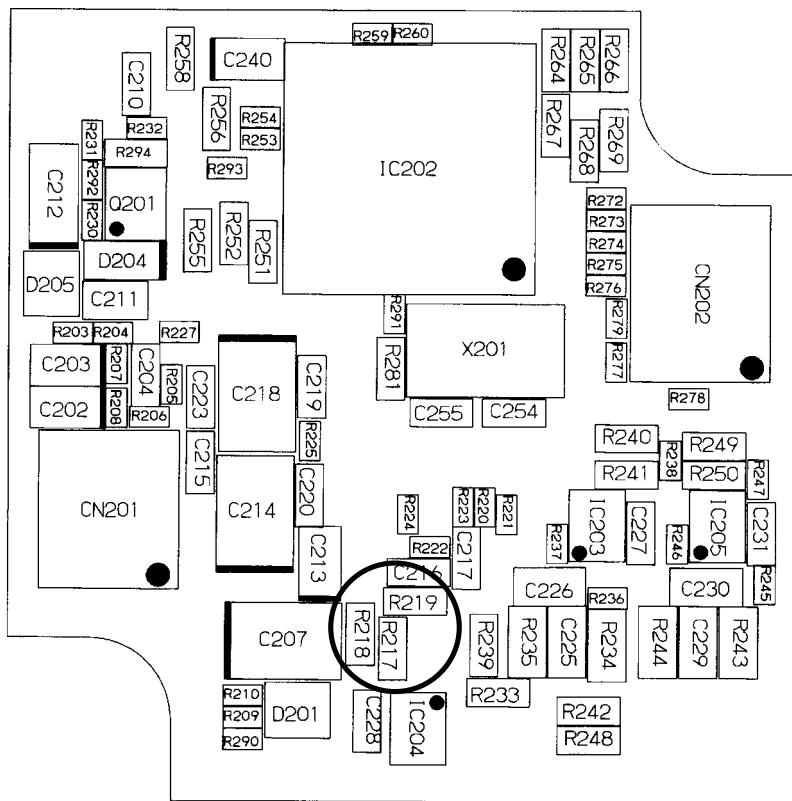

Location of chip capacitors (Main board side B)

## 11-3 Auto electronic shutter on / off

Factory setting for auto electronic shutter is off. If necessary, it can be set to on. Absent the R259, R260 chip to set the auto electronic shutter to on.

Auto electronic shutter	R259	R260	
OFF	0Ω	0Ω	Factory setting
ON	Absent	Absent	

0Ω : Part code                    RME2068  
 Description                    ERJ2GE0R00X

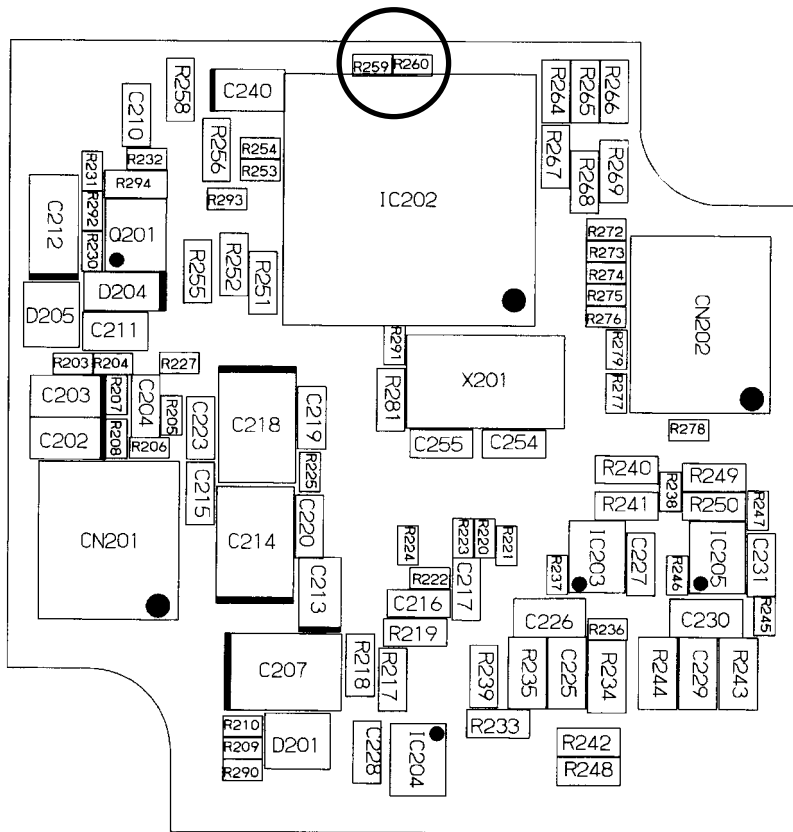

Location of chip resistors (Main board side B)



**11-4 Changes to fixed shutter mode**

The fixed shutter mode can be changed by replacing the chip parts indicated below.

Mode	R259	R260	R261	R262	R263	R264	R265	R266	R267	R268	R269	Factory setting
Normal mode	0Ω	0Ω	Absent	0Ω	Absent	6800	10k	27k	10k	10k	27k	
Auto electronic shutter mode	Remove	Remove	Absent	0Ω	Absent							
Fixed shutter mode	EIA 1/100	Remove	0Ω	0Ω	Remove	Absent	0Ω	0Ω	Remove	0Ω	0Ω	Remove
	CCIR 1/120								Remove	Remove	0Ω	
	1/250								Remove	Remove	0Ω	
	1/500			Absent	Remove	0Ω			0Ω	0Ω	Remove	
	1/1000								Remove	Remove	0Ω	
	1/2000	↑	↑	0Ω	Remove	Absent	Remove	Remove	0Ω	0Ω	0Ω	Remove
	1/5000						↑	↑	0Ω	Remove	Remove	0Ω
	1/10000			Absent	Remove	0Ω			0Ω	0Ω	0Ω	Remove
	1/100000								0Ω	Remove	Remove	0Ω

R259 , R260 : 0Ω Part code  
Description  
Others : 0Ω Part code  
Description

RME2068  
ERJ2GE0R00X  
RME1784  
ERJ3GEYJ0R00V

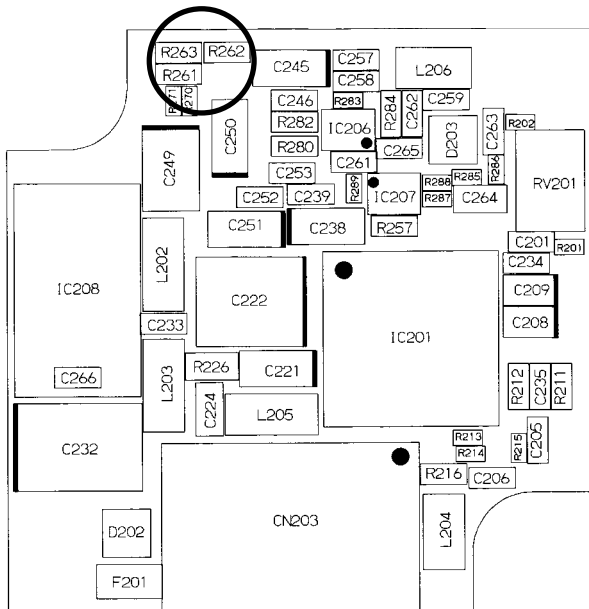

(Main board side A)

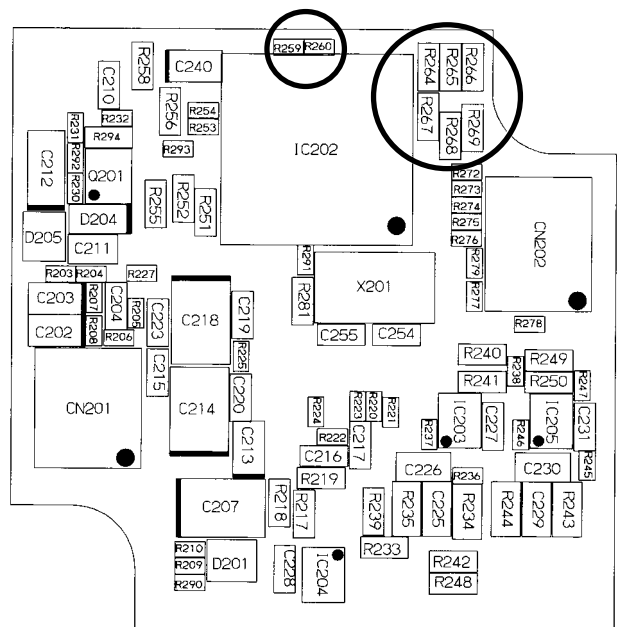

(Main board side B)

Location of chip resistors

## 11-5 BE-IR20 external sync

The BE-IR20 factory setting is for internal sync. If required, this can be changed to external sync by changing chip parts.

Change the following chip parts for external sync operation.

Sync system	R280	R281	R282	R284	
Internal	100 Ω	Absent	Absent	0 Ω	Factory setting
External	Delete	0 Ω	100 Ω	Delete	

0 Ω : Part code RME1784  
Type ERJ3GEYJ0R00V

100 Ω : Part code RME1797  
Type ERJ3GEYJ101V

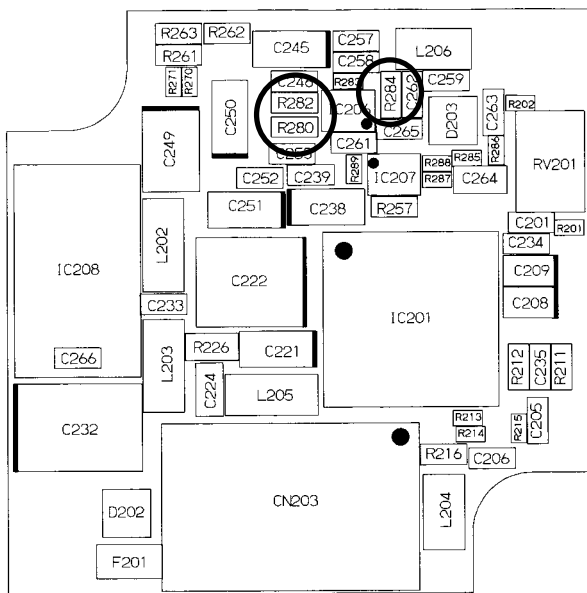

(Main board side A)

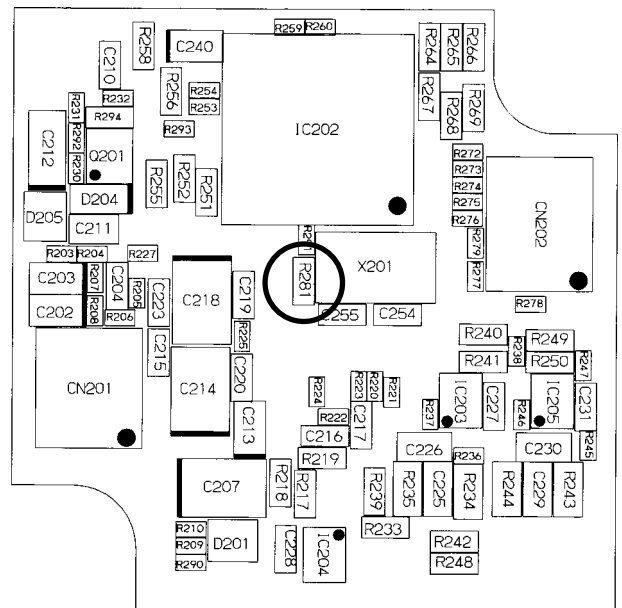

(Main board side B)

Location of chip resistors

## 11-6 BE-IR21 internal sync

The BE-IR21 factory setting is for external sync. If required, this can be changed to internal sync by changing chip parts.

Change the following chip parts for internal sync operation.

Sync system	R280	R281	R282	R284	
External	Absent	0 Ω	100 Ω	Absent	Factory setting
Internal	100 Ω	Delete	Delete	0 Ω	

0 Ω : Part code RME1784  
 Type ERJ3GEYJ0R00V  
 100 Ω : Part code RME1797  
 Type ERJ3GEYJ101V

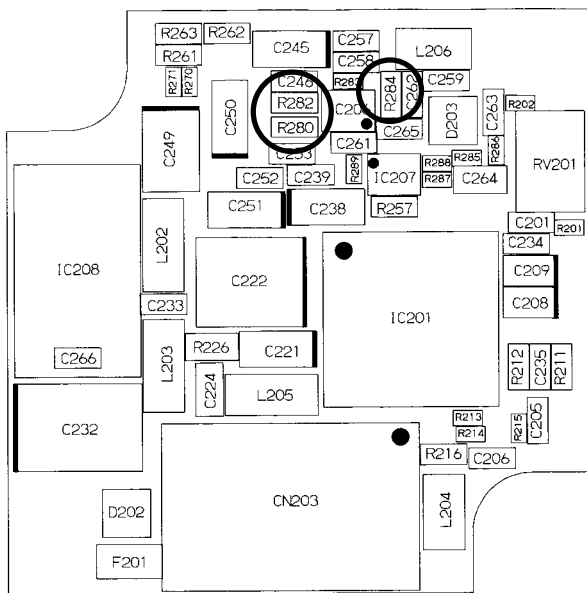

(Main board side A)

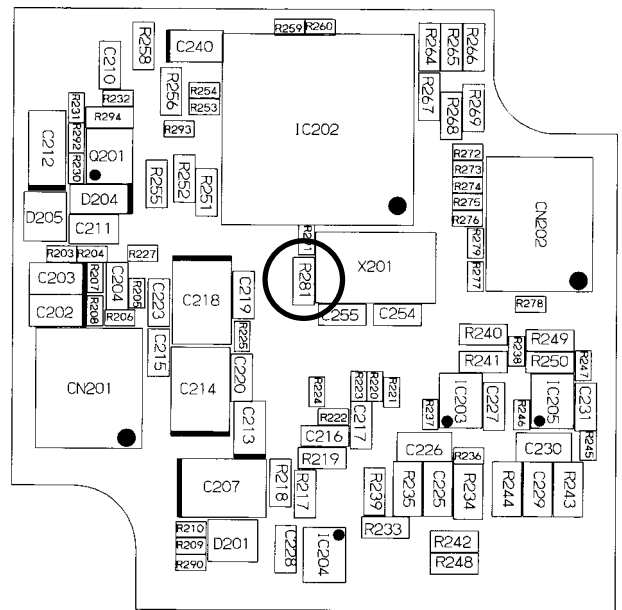

(Main board side B)

Location of chip resistors

## 11-7 HD and VD output (BE-IR20 only)

The BE-IR20 can be provided with horizontal and vertical drive outputs by changing chip parts. Change the following chip parts to provide HD and VD outputs.

	R233	R239	R240	R241	R242	R248	R249	R250
Factory setting	0 Ω	Absent	0 Ω	Absent	0 Ω	Absent	0 Ω	Absent
HD & VD output	Delete	0 Ω	Delete	0 Ω	Delete	0 Ω	Delete	0 Ω

0 Ω : Part code RME1784  
Type ERJ3GEYJ0R00V

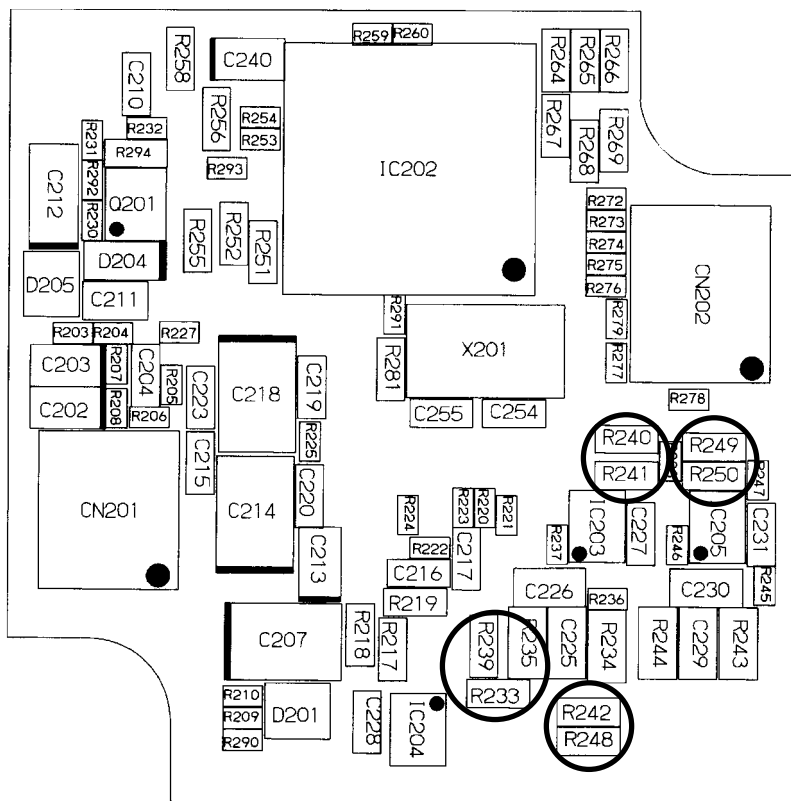

Location of chip resistors(Main board side B)

Connector pin assignments after change

Pin No.	Signal
1	Video out
2	Video GND
3	GND
4	+9V
5	HD out
6	VD out
7	HD/VD GND

**Note:** The accessory cable cannot be used for signal outputs.

## 12. Options

LA-IR20 Mount adapter dimensions

MASS : APPROX. 60 g

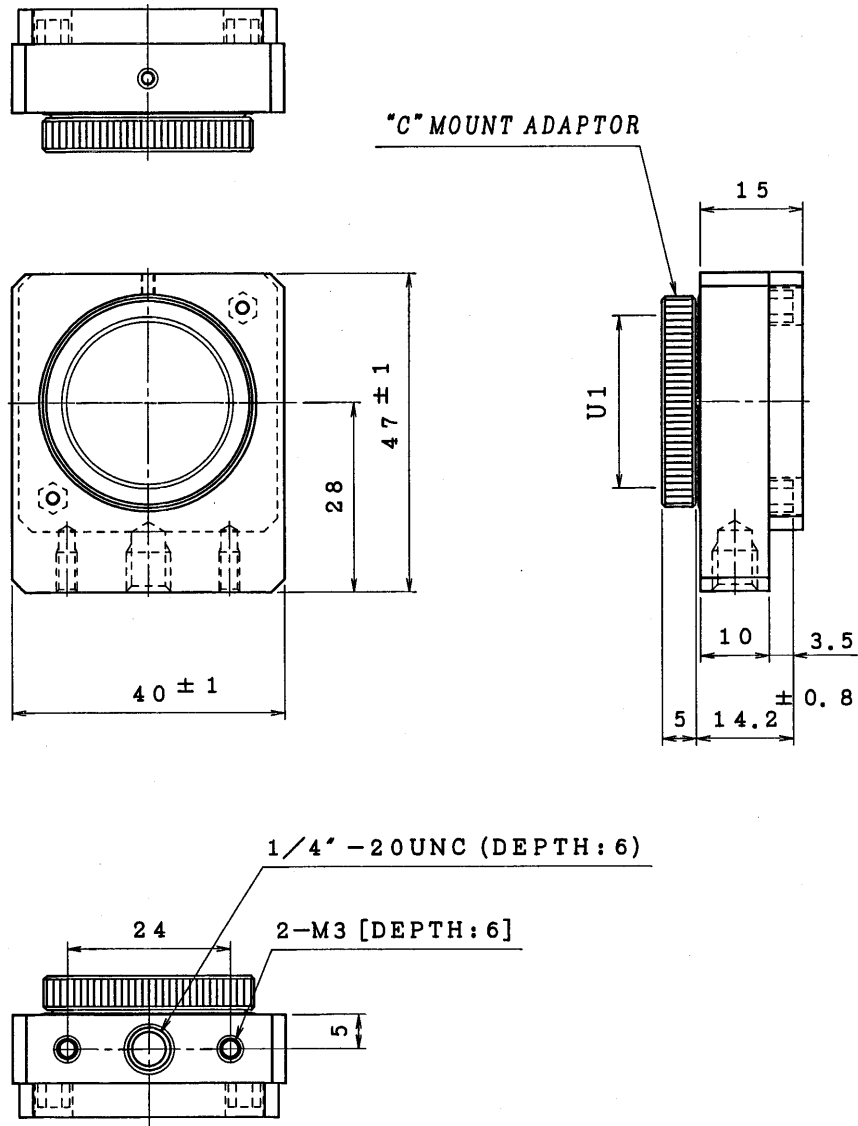

Remove c-mount attachment to use as cs-mount.

BE-IR20/21 and LA-IR20 combined dimensions

MASS : APPROX. 75 g  
( WITHOUT CABLE ASSY. )

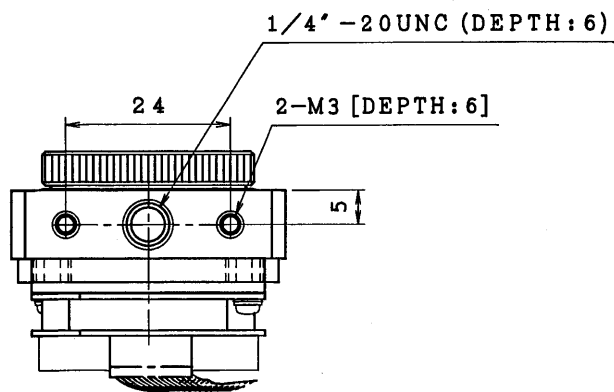
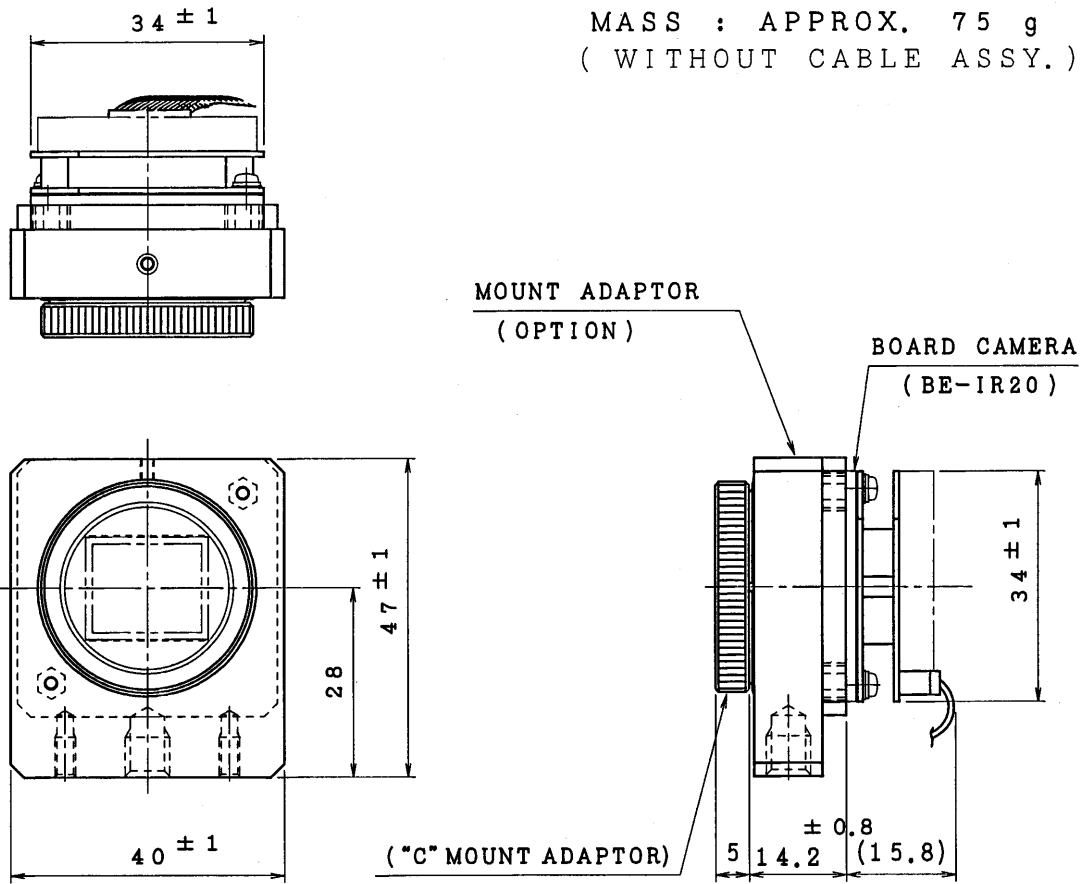

Spectral sensitivity (typical example)

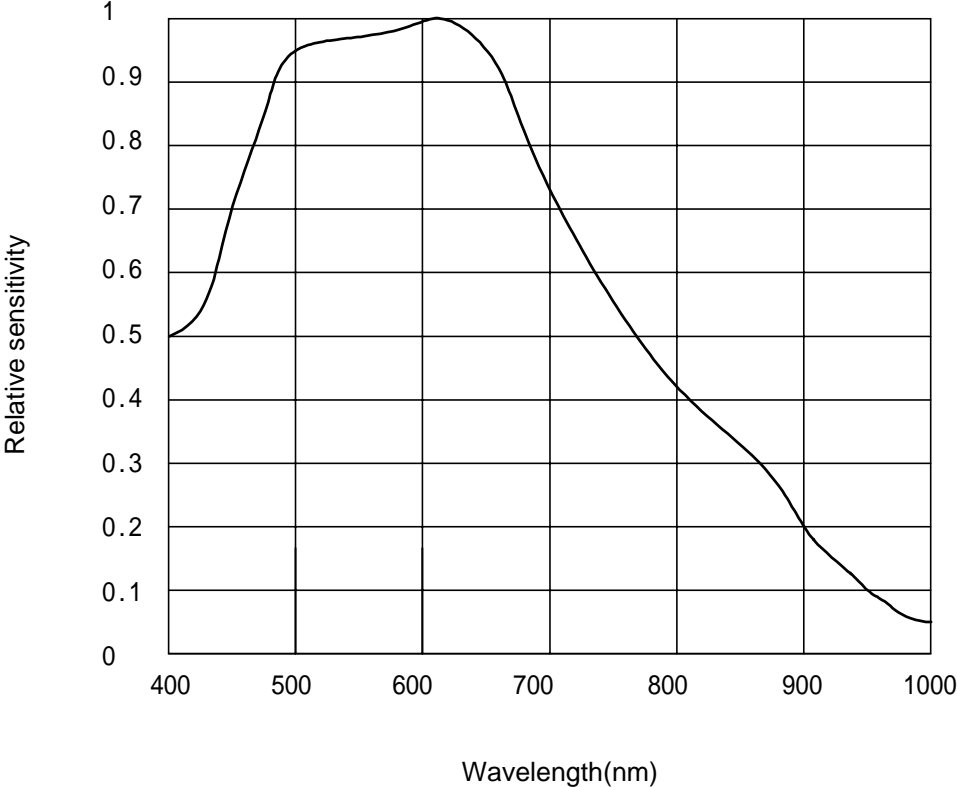

Caution	
---------	--

The specifications of this equipment are subject to change without notice for improvement.  
Prior to placing your order , be sure to confirm that these specifications are the latest ones.  
Hitachi Denshi guarantee that the equipment shipped from our factory conforms to the Hitachi Denshi's standard warranty conditions and perform quality control within the range necessary to perform the warranty.

Warranty and After-sales Service	
----------------------------------	--

- (1) The guarantee period is one year after the date of purchase. However , the defects due to erroneous use or intentional act are excluded.
- (2) As the defect after expiration of the guarantee period , Hitachi Denshi will repair the equipment if the intended function is restored by the repair work , and the cost is changed to a customer.
- (3) Hitachi Denshi is not liable for the losses caused when the equipment is used in a system used for business trades , production process , medical fields , crime prevention applications , etc.
- (4) The parts used in the equipment have their respective lives. The lives of such parts will be shortened under the environments of high temperature or high humidity. When the stable operation is required for a long time , it is recommended to perform periodical maintenance and inspection every year or every two years.

Dec 27 2000

Jul 24 2000

Dec 9 1999

Aug 5 1999